

# Fosroc® Conbextra HF

**High-flow, non-shrink, cementitious grout conforming to the requirements of BS EN 1504-3 Class R4 and BS EN 1504-6: Anchoring of reinforcing steel bar.**

## Uses

Conbextra HF is used for free flow, non-shrink, cementitious grouting of gap thicknesses 10 to 100 mm. Recommended applications include:

- Large stanchion baseplates
- Joints between pre-cast concrete panels
- Pumped grouting applications
- Grouting applications where pouring access is restricted
- Anchoring of reinforcing steel bars
- Installation of tie bars

## Advantages

- Non-shrink
- Highly flowable
- High early age strength
- Chloride free
- Suitable for pumping
- Conbextra HF complies with LU Standard 1-085 'Fire Safety Performance of Materials'.

## Description

Conbextra HF is supplied as a ready to use dry powder. The addition of a controlled amount of clean water produces a free-flowing grout for gap thicknesses up to 100 mm. In addition the low water requirement ensures high early strength and long-term durability.

Conbextra HF is a blend of Portland cements, graded fillers and chemical additives. The filler grading produces a highly flowable grout which will not segregate or bleed.

## Specification clause

The grout shall be Conbextra HF, a pre-bagged, single component cementitious material which conforms with the requirements of BS EN 1504-3 class R4 and BS EN 1504-6. The grout shall fully conform to the requirements of US Army Corps of Engineers Specification for non-shrink grout CRD-C621-82A

It shall be mixed with clean water to the required consistency and not exhibit bleed or segregation

A volumetric expansion of up to 1% shall occur while the grout is in a plastic state by means of a gaseous system.

The compressive strength of the grout must exceed 40 MPa at 7 days and 65 MPa at 28 days.

The storage, handling and placement of the grout must be in strict accordance with the manufacturer's instructions

## Standards compliance

Conbextra HF complies with classification R4 according to BS EN 1504-3.

Conbextra HF complies with the requirements of BS EN 1504-6 : Anchoring of reinforced steel bar.

Conbextra HF conforms fully to U.S. Corps of Engineers Specification for non-shrink grout CRD-C621-82A and ASTM C1107-91 (Type C).

 <b>0370</b> <b>09</b> <b>0370-CPR-0845</b>	
<b>DOP: UK9-10</b>	
<b>Fosroc International Limited</b> <small>Drayton Manor Business Park, Coleshill Road, Tamworth, B78 3TL, UK</small>	
<b>Conbextra HF</b>	
<b>EN1504-3: Structural and non-structural repair methods 3 and 4</b> <b>EN 1504-6: Anchoring of reinforcing steel bar</b>	
Compressive strength	Class R4 ( $\geq 45$ MPa)
Adhesion strength by pull-off test	$\geq 2.0$ MPa
Chloride ion content	$\leq 0.05\%$
Thermal compatibility: freeze thaw cycling with immersion	$\geq 2.0$ MPa
Carbonation resistance	Passes
Elastic modulus	32.7 GPa
Testing of anchoring products by the pull-out method	$\leq 0.6$ mm at 75 kN load
Fire classification	Class A1
Dangerous substances	Complies with 5.3 (EN1504-6) 5.3 (EN1504-3)



# Fosroc® Conbextra HF

## Properties

The following results were obtained at a water : powder ratio of 0.192 and a temperature of 20°C unless otherwise stated.

Test Method	Standard	EN1504 Requirement	Result
Compressive Strength	EN 12190:1999	Class R4 $\geq$ 45 MPa	@ 1 Day 22 MPa @ 7 Day 55 MPa @ 28 Days 70 MPa
Bond strength by pull off:	EN 1542:1999	Class R4 $\geq$ 2.0 MPa	2.6 MPa
Chloride ion content:	EN 1015-17:2000	Class R4 $\leq$ 0.05 %	0.04%
Freeze thaw cycling:	EN 13687-1:2002	Class R4 $\geq$ 2.0 MPa	2.4 MPa
Resistance to carbonation $d_k$	EN 13295:2005	Class R4 $\leq$ ref concrete	Conforms
Elastic Modulus in Compression	EN 13412	Class R4 $\geq$ 20 GPa	32.7 GPa @ 28 days
Testing of anchoring products by pull out method	EN 1881:2006	@ 75 KN load $\leq$ 0.6 mm	0.44 mm Dry Test 0.43 mm Wet Test
Fire rating	EN 1504-3 cl.5.5	-	Class A1 Non-Combustible
Flexural strength	BS 6319 Pt 3:1990	-	5.5 MPa @ 28 days
Tensile strength	BS 6319 Pt 3:1985	-	3.7 MPa @ 28 days
Setting time	BS 4551 Pt14:1980	-	Initial set: 6 hours
Fresh wet density		-	Nominally 2130 kg/m <sup>3</sup>
Alkali reactive particles	Method TI-B 52	-	$\leq$ 1.0 vol %
Flow Characteristics ( efflux time)	CRD-C Cone	-	26 - 35 Seconds
Grout consistency / Water addition	CRD-C621-82A definitions	-	Flowable: 4.5 litres water/ 25kg bag Fluid: 4.8 litres water/ 25kg bag
Minimum thickness	-	-	10 mm
Maximum thickness	-	-	100 mm

**Clarification of property values:** The typical properties given above are derived from laboratory testing. Results derived from field applied samples may vary.

## Consistency of mixed grout

The flow distances given below are intended as a guide. Actual flow distances will vary depending on site conditions:

Gap depth mm	Flowable 100 mm head	Flowable 250 mm head	Fluid 100mm head	Fluid 250mm head
10	360 mm	1200 mm	900 mm	2500 mm
20	950 mm	2600 mm	1900 mm	3000 mm
30	1500 mm	3000 mm	3000 mm	3000+ mm
40	2200 mm	3000+ mm	3000+ mm	3000+ mm
50	3000 mm	3000+ mm	-	-

# Fosroc® Conbextra HF

## Application instructions

### Preparation

#### Foundation surface

The substrate surface must be free from oil, grease or any loosely adherent material. If the concrete surface is defective or has laitance, it must be cut back / scabbled to a sound base. Bolt holes or fixing pockets must be blown clean of any dirt or debris.

#### Pre-soaking

For a minimum of 2 hours prior to grouting, the area of cleaned foundation should be flooded with fresh water. Immediately before grouting takes place, any free water should be removed. Particular care should be taken to blow out all bolt holes and pockets. Where water soaking is impossible contact Fosroc Technical Service.

#### Base plate

It is essential that this is clean and free from oil, grease or scale. Air pressure relief holes should be provided to allow venting of any isolated high spots.

#### Levelling shims

If these are to be removed after the grout has hardened, they should be treated with a thin layer of grease.

#### Formwork

The formwork should be constructed to be leakproof as Conbextra HF is a free-flowing grout. This can be achieved by using foam rubber strip or Nitoseal MS60\* beneath the constructed formwork and between joints.

In some cases it is practical to use a sacrificial semi-dry sand and cement formwork. The formwork should include outlets for the pre-soaking water.

The unrestrained surface area of the grout must be kept to a minimum. Generally the gap width between the perimeter formwork and the plate edge should not exceed 150 mm on the pouring side and 50 mm on the opposite side. There should be no gap at the flank sides.

#### Mixing

For mixing quantities up to 50 kg a high power, 280 to 640 rpm, 110 volt drill, fitted with a Conbextra Mixing Paddle (MR3) is suitable. For best results a mechanically powered grout mixer should be used. Larger quantities will require a high shear vane mixer. Do not use a colloidal impeller mixer.

It is essential that machine mixing capacity and labour availability is adequate to enable the grouting operation to be carried out continuously. This may require the use of a holding tank with provision for gentle agitation to maintain fluidity.

Prior to the first mix the vessel should be wetted and drained. The selected water content 4.5 - 4.8 litres per 25 Kg (see table) should be accurately measured into the mixer. Slowly add the total contents of the Conbextra HF bag, mix continuously for 5 minutes, ensuring a smooth, even consistency is obtained.

#### Placing

Place the grout within 20 minutes of mixing to gain the full benefit of the expansion process.

Conbextra HF can be placed in thicknesses up to 100 mm in a single pour.

For thicker sections use Conbextra TS grout.

Any bolt pockets must be grouted prior to grouting between the substrate and the base plate.

Continuous grout flow is essential.

Example of a typical hopper system:

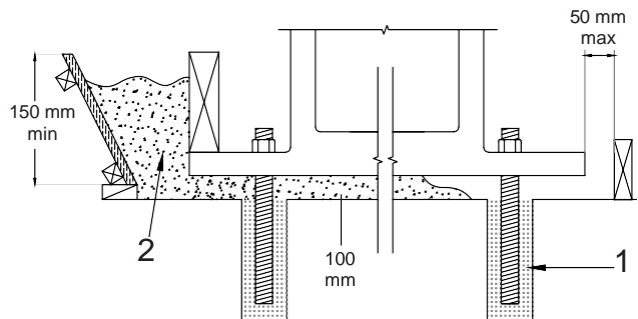

1. Conbextra HF or Lokfix\* (first stage)

2. Conbextra HF poured or pumped into removable hopper (second stage)

\* Also available from Fosroc.\*

Sufficient grout must be available prior to starting and the time taken to pour a batch must be regulated to the time taken to prepare the next one.

The mixed grout should be poured only from one side of the void to eliminate the entrapment of air or surplus pre-soaking water. This is best achieved by pouring the grout across the shortest distance of travel. The grout head must be maintained at all times so that a continuous grout front is achieved.

# Fosroc® Conbextra HF

Where large volumes have to be placed, Conbextra HF may be pumped. Screw feed and piston pumps are suitable for this purpose.

When the Conbextra HF has reached trowellable consistency, the unrestrained portion should be cut back to the baseplate/ bearing plate.

## Curing

On completion of the grouting operation, exposed areas should be thoroughly cured with Concure WB curing membrane, continuous application of water and/or wet hessian.

## Anchoring applications

Holes should be drilled with a rotary percussive air flush drill and deformed bars should be used. Diamond cored holes should be roughened or under-reamed. The holes should be prewetted for a minimum of 2 hours prior to grouting. Remove water before grouting.

The mixed grout should be poured into the hole and the bar pushed through the grout

## Cleaning

Conbextra HF should be removed from tools and equipment with clean water immediately after use. Cured material can be removed mechanically, or with Fosroc Acid Etch.

## Estimating

### Supply

Conbextra HF is supplied in 25 kg bags.

### Yield

Allowance should be made for wastage when estimating quantities required. The approximate yield per 25 kg bag for different consistencies is:

Consistency	Flowable	Fluid
Yield:	13.25 litres	13.5 litres

## Limitations

### Low temperature working

When the air or contact surface temperatures are 5°C or below on a falling thermometer, warm water (30°C to 40°C) is recommended to accelerate strength development. Substrates should be free from ice.

For ambient temperatures below 10°C the grout consistency should be flowable and the formwork should be maintained in place for at least 36 hours.

Normal precautions for winter working with cementitious materials should then be adopted, specifically protecting the grout from freezing in the first 24 hours after placing.

### High temperature working

At ambient temperatures above 35°C the mixed grout should be stored in the shade. Cool water (below 20°C) should be used for mixing the grout.

## Storage

Store unopened bags in cool dry internal conditions. Conbextra HF has a shelf life of 12 months if kept in a dry store in sealed bags. If stored in high temperature and high humidity locations the shelf life may be reduced to less than 6 months.

Conbextra HF is not supplied in waterproof packaging; individually or palletised.

## Precautions

### Health and safety

For further information refer to appropriate Product Safety Data Sheet available at [www.fosroc.com](http://www.fosroc.com)

### Fire

Conbextra HF is non-flammable.

## Environmental Data (EPD)

GWP Total, A1 – A3: 0.407 kgCO<sub>2</sub>e per 1kg product.

GWP Total, A1 – D: 0.611 kgCO<sub>2</sub>e per 1kg product.

Fosroc and Conbextra are trademarks of Fosroc International Limited



## Fosroc International Limited

Drayton Manor Business Park  
Coleshill Road, Tamworth,  
Staffordshire B78 3XN, UK

[www.fosroc.com](http://www.fosroc.com)

### Important note

Fosroc products are guaranteed against defective materials and manufacture and are sold subject to its standard Conditions for the Supply of Goods and Services, copies of which may be obtained on request. Whilst Fosroc endeavours to ensure that any advice, recommendation, specification of information it may give is accurate and correct, it cannot, because it has no direct or continuous control over where or how its products are applied, accept any liability either directly or indirectly arising from the use of its products, whether or not in accordance with any advice, specification, recommendation of information given. All Fosroc datasheets are updated on a regular basis. It is the user's responsibility to obtain the latest version.

telephone:  
+44 (0)1827 262222

email:  
[enquiryuk@fosroc.com](mailto:enquiryuk@fosroc.com)

